

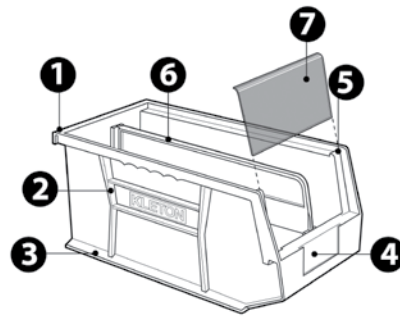

## Kleton Stack & Hang Bins

- Designed to hang from bin racks, panels, rails and carts
- Bins reduce and control inventories, shorten assembly times and minimize parts handling
- Reinforced ribs, on both sides, prevent bins from spreading under loads
- Front, back and side grips for easy handling
- Stackable

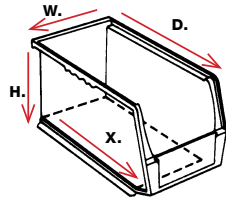
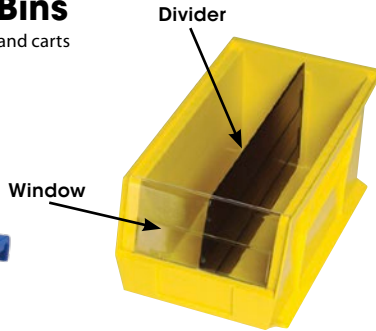

1. Full width hanger supports bins when suspended from louvered panels or rails
2. Reinforced rib design adds strength and prevents spreading when stacked
3. Extra-wide ledges for secure stacking and stability
4. Large front label slots ideal for larger bar code scanning and content identification
5. Anti-slide stop prevents stacked bins from shifting forward
6. Optional dividers increase storage options
7. Optional windows maximize storage capacity, prevent spillage and protect parts from dust and dirt

Blue	Red	Yellow	Green	Black	Series	Outside Dimensions			Inside Dimensions			Bottom Depth X"	Load Cap. lbs.	Price /Each	Uses Divider	Price /Each	Uses Clear Window	Price /Each	
						W"	x	D"	x	H"	W"								x
CF820	CF822	CF823	CF821	CF824	30210	4-1/8	x	5-3/8	x	3	3-7/16	x	4-3/4	x	2-13/16	4	10	CB825	-
CF825	CF827	CF828	CF826	CF829	30220	4-1/8	x	7-3/8	x	3	3-7/16	x	6-3/4	x	2-13/16	6	10	CB826	-
CF830	CF832	CF833	CF831	CF834	30230	5-1/2	x	10-7/8	x	5	4-3/8	x	10-1/4	x	4-3/4	9	30	CB829	CB814
CF835	CF837	CF838	CF836	CF839	30235	11	x	10-7/8	x	5	10	x	10-1/4	x	4-3/4	9	50	CB829	CB815
CF840	CF842	CF843	CF841	CF844	30239	8-1/4	x	10-3/4	x	7	6-9/16	x	10	x	6-3/4	8	50	CB830	CB818
CF845	CF847	CF848	CF846	CF849	30240	8-1/4	x	14-3/4	x	7	6-9/16	x	14	x	6-3/4	12	60	CB831	CB818
CF850	CF852	CF853	CF851	CF854	30250	16-1/2	x	14-3/4	x	7	14-3/4	x	14	x	6-3/4	12	75	CB831	CB819

## Dividers

- Maximizes flexibility, keeps contents organized
- Allows for the separation of contents in bins
- Installed in a back to front position



Model No.	Description	Dividers per Case	Price/Each
CB825	For 5-3/8" D x 3" H Bin	6	
CB826	For 7-3/8" D x 3" H Bin	6	
CB829	For 10-7/8" D x 5" H Bin	6	
CB830	For 10-3/4" D x 7" H Bin	6	
CB831	For 14-3/4" D x 7" H Bin	6	

## Clear Windows

- Crystal styrene window front increases bin capacity
- Provides quick view on bin contents
- Snaps quickly into place



Model No.	Description	Windows per Case	Price/Each
CB814	5-1/2" W x 5" H	12	
CB815	11" W x 5" H	6	
CB818	8-1/4" W x 7" H	6	
CB819	16-1/2" W x 7" H	6	

## Clear Cover

- Provides high visibility and accessibility to bin contents
- Easy snap-in installation due to integrated hinge pins
- Clear covers protects from dust, dirt, and debris
- Can be used with dividers



Model No.	Description	Covers per Case	Price/Each
CF855	For 5-3/8" D x 4-1/8" W x 3" H Bin	24	
CF856	For 7-3/8" D x 4-1/8" W x 3" H Bin	24	
CF857	For 10-7/8" D x 5-1/2" W x 5" H Bin	12	
CF858	For 10-7/8" D x 11" W x 5" H Bin	6	
CF859	For 10-3/4" D x 8-1/4" W x 7" H Bin	6	
CF860	For 14-3/4" D x 8-1/4" W x 7" H Bin	12	

## Recycled Plastic Bins

- Manufactured from recycled 100% post consumer, high density polyethylene
- Available in black only



Model No.	Mfg. No.	Outside Dimensions			Price /Each	Dividers	Price /Each
		W"	x	D"	x	H"	
CC553	QUS210BR	4/18	x	5 3/8	x	3	CB825
CC554	QUS220BR	4/18	x	7 3/8	x	3	CB826
CC555	QUS230BR	5 1/2	x	10 7/8	x	5	CB829
CC558	QUS235BR	11	x	10 7/8	x	5	CB829
CC559	QUS239BR	8 1/4	x	10 3/4	x	7	CB830
CC560	QUS240BR	8 1/4	x	14 3/4	x	7	CB831
CC562	QUS250BR	16 1/2	x	14 3/4	x	7	CB831